

EIRICH Laboratory Mixer Type EL5/10 *Profi*

for high demands in research,
development and production



Mixing



Granulating



Coating



Kneading



Dispersing

EIRICH Laboratory Mixer EL5/10 Profi

Flexible high-performance mixing system for challenging tasks in the fields of research, development and small-scale production

Process materials from dry to plastic and pasty can be processed.

Applications

The multi-functional mixing system can be used for many different applications, e.g. for mixing, granulating, coating, kneading, dispersing, dissolving, defibering and many more.

Industrial scale-up of test results is possible.

Feeding

Once the tools have been retracted, the raw materials and fluids are filled in from above through openings that can be sealed dust-tight.

Emptying

First of all, the mixing tools are moved out conveniently with electric motors. Then the mixing pan can simply be taken off for emptying.

Drives / motors

Mixing pan: Pole-changing helical-worm geared motor with 2 speed steps

Mixing tool: Two basic speed ranges can be set up via V-belts. Within these ranges, the speed can be infinitely varied in both directions of rotation thanks to the integrated frequency converter.

Power connection: CEE three-phase plug 400V / 16A

Service and cleaning

All bearings are maintenance-free and greased for service life. All parts that come into contact with the process material are made of stainless steel as standard and are easy to clean.

Mixing principle

A **rotating and tilted mixing pan (1)** with an eccentrically arranged **mixing tool (2)** produces optimum mixing results in the shortest possible time. In the process, **the fixed scraper on the wall (3)** performs the cleaning of the mixing pan wall and promotes the movement of the process material.

Thanks to the different geometries of the interchangeable mixing tools and the option of varying their speed within wide limits, the system setup can be perfectly adjusted to meet the needs of completely different tasks and consistencies.

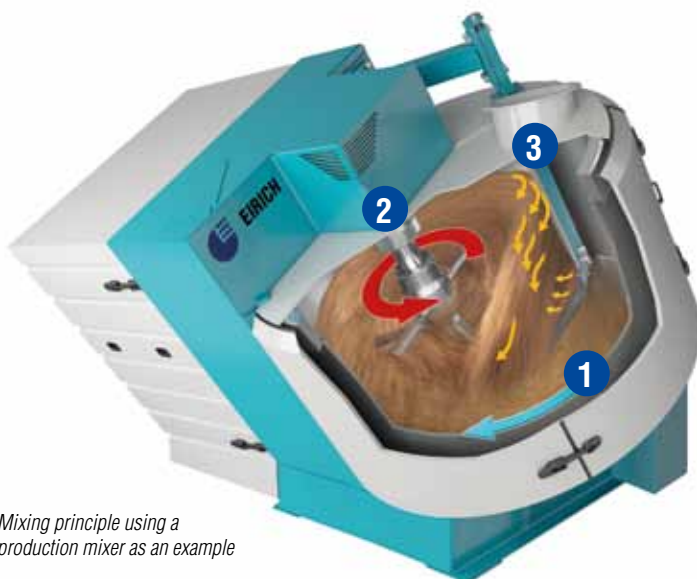

Mixing principle using a production mixer as an example

With enhanced operating comfort

Features of the basic equipment

- Mixing pan: INOX
- Mixing tool: Star-type rotor
EL5 Profi: modular layout, made of stainless steel
EL10 Profi: single-unit layout, with armoring
- Control system: Eco Control – all functions can be operated safely and reliably via selector switches
- Process material temperature: 180°C max.

Mixing tool variants

- Pin-type rotor instead of star-type rotor
- EL5 Profi: Wear protection via armoring for pin-type rotor or star-type rotor
- Micro-granulation rotor with tungsten carbide wear protection

Additional options

- Basic Touch Control with the following features:
 - Easy-to-read operator panel with 4" TFT touch display
 - Adjustment of operating parameters and display of current machine data such as tool speed, motor output, torque and temperature (provided the optional temperature measurement instrument has been selected)
 - Measurement diagrams for displaying real-time trends
 - Integrated stopwatch with shutdown function
- Temperature measurement on the wall scraper (PT100)
- Interchangeable edge of the wall scraper optionally made of PTFE, polyamide (max. 80°C) or tungsten carbide (basic equipment: Ampco)
- Support for mixer inclination of 0° for fluids or fluidizing materials
- Roller table with mixer tilt adjustment as a flexible base frame
- Instruction and training at the EIRICH Test Center in Hardheim



Basic Touch Control

Eco Control

INOX mixing pan – usable capacity 5 liters max.

Technical data for your planning

Dimensions and weights			EL5 Profi	EL10 Profi
Machine	H1/H2	mm	900/1200	
	L	mm	930	970
	Width	mm	510	510
	Weight	kg	180	190
Mixing pan	Diameter	mm	235	315
	Capacity*	Liters	3-5	8-10
		kg	max. 8	max. 12

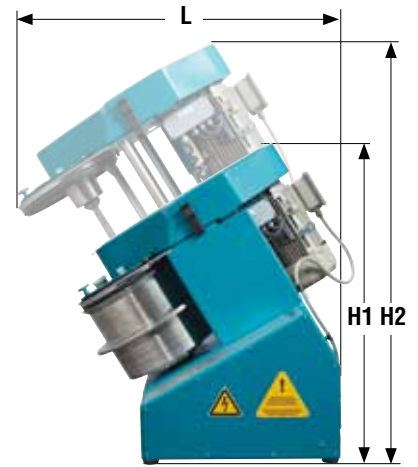

Performance data				
Mixing pan	Drive (2-stage speed)	kW	0.55 / 0,88	
Mixing tool	Drive	kW	up to 4	
	Circumferential speed	m/s	0.5 - 32	0.7 - 40

*depending on the product



*EL 10 Profi:
With INOX mixing pan –
usable capacity 10 liters max.*